

Series TMV

THERMOSTATIC EXPANSION VALVES INTERCHANGEABLE ORIFICE CARTRIDGE

PRODUCT DATA

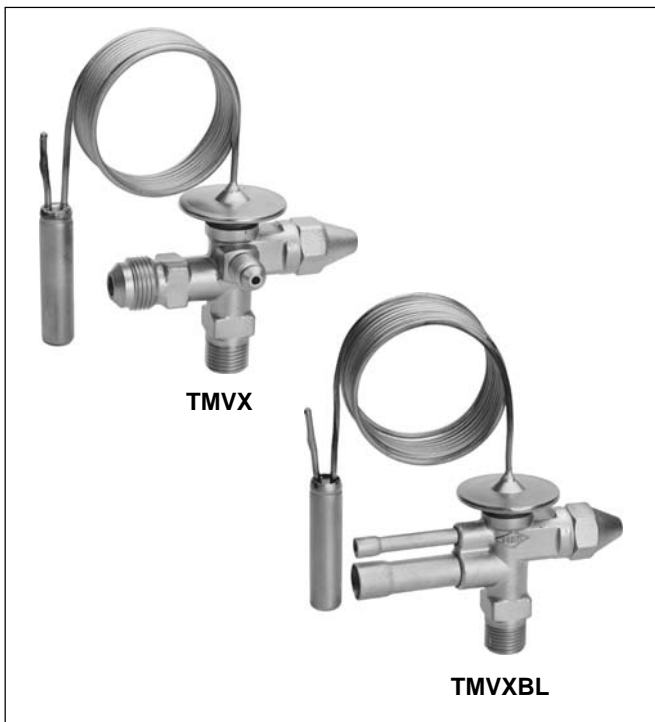

Features

- **TMV / TMVBL:** with internal pressure equalisation; for single injection in installations with one or more cooling circuits
- **TMVX / TMVXBL:** with external pressure equalisation; for optimal evaporation effectiveness in all applications. Obligatory for multiple injection by liquid distributors
- **Combi adsorber charge.**
The same valve can be used for different refrigerants (see table on page 2)
 - Controller charge is high sensitive and responsive thus lowest possible level of superheat can be achieved
 - Charge is not sensitive to effects of temperature on the capillary tube and valve head
 - damping characteristic results in stable control behaviour
- Suitable for systems with hot gas defrosting
- Adjustable superheat setting
- Flare connections: TMV, TMVX
- Flare / solder connections: TMVBL, TMVXBL
- Extreme durable due to stainless steel head and stainless steel diaphragm welded using protective gas
- Interchangeable orifice cartridges
- Refrigerants: R134a, R401A, R12
R22, R407C, R407A
R404A, R507, R402A, R407B, R502

Application

Thermostatic expansion valves series TMV are used in general refrigeration and for original equipment. Plants with one or more circuits such as refrigerated cabinets even with cramped mounting conditions, ice and cream machines, milk cooling units, water chillers, vehicle air conditioning systems, cold stores, and air conditioning systems.

Materials

Body	brass
Thermal head	stainless steel
Connection	solder: copper flare: brass

Specification

Nominal capacity range	0.5 to 21.5 kW R22 (small orifice graduation for optimal control behaviour, interchangeable orifice cartridges)
Evaporating temperature range	see table on page 2
Maximum pressure PS	29 bar
Maximum test pressure	32 bar
Max. ambient temperature	100 °C
Max. bulb temperature	140 °C
Static superheat	approx. 3 K
Length of capillary tube	1.5 m
Bulb diameter	12 mm

Thermal Charges and Temperature Ranges

1. Adsorber charge

Refrigerant	Evaporation temperature range
R134a, R401A, R12	+15 °C to -30 °C
R22, R407C, R407A	+15 °C to -45 °C
R404A, R507, R402A, R407B, R502	±0 °C to -50 °C

Further refrigerants on request.

Thermal systems with adsorber charge are completely insensitive to effects of temperature on the capillary tube and valve head. It reacts only according to the temperature of the bulb.

Thus, Honeywell TMV valves with combi adsorber charge work absolutely reliable, even in icy condition or while defrosting using hot gas.

2. Adsorber charge with pressure limiting performance MOP

Refrigerant	Evaporation temperature range	MOP
R134a, R401A, R12	+5 °C to -30 °C	MOP A +15 °C
	-10 °C to -30 °C	MOP A ±0 °C
R22, R407C, R407A	+5 °C to -45 °C	MOP A +15 °C
	-10 °C to -45 °C	MOP A ±0 °C
	-27 °C to -45 °C	MOP A -18 °C
R404A, R507, R402A, R407B, R502	-10 °C to -50 °C	MOP A ±0 °C
	-20 °C to -50 °C	MOP A -10 °C
	-27 °C to -50 °C	MOP A -18 °C

Further refrigerants and MOP on request

Capacities

Type	Orifice size	Nominal capacity (kW)*		
		R134a	R22 R407C	R404A R507
TMV TMVX TMVBL TMVXBL	0.3	0.34	0.50	0.37
	0.5	0.65	1.0	0.70
	0.7	0.90	1.3	1.0
	1.0	1.3	1.9	1.5
	1.5	2.1	3.1	2.3
	2.0	2.7	3.9	2.9
	2.5	3.8	5.6	4.2
	3.0	6.2	8.9	6.7
	3.5	8.2	11.7	8.8
	4.5	11.1	16.3	12.3
4.75	15.0	21.5	16.2	

* Capacities are based on $t_o = -10\text{ °C}$, $t_c = +25\text{ °C}$ and 1 K subcooled liquid refrigerant entering the valve.

For other operating conditions see capacity charts in Honeywell catalogue or consult the Honeywell software.

Dimensions and Weights

Type	Connections			Weight (kg)
	Inlet (B)	Outlet (A)	Pressure equaliser (C)	
TMV	5/8" UNF	3/4" UNF	-	approx. 0.35
TMVX	5/8" UNF	3/4" UNF	7/16" UNF	approx. 0.36
TMVBL	5/8" UNF	12 mm ODF	-	approx. 0.33
	5/8" UNF	1/2" ODF	-	
TMVXBL	5/8" UNF	12 mm ODF	6 mm ODF	approx. 0.34
	5/8" UNF	1/2" ODF	1/4" ODF	

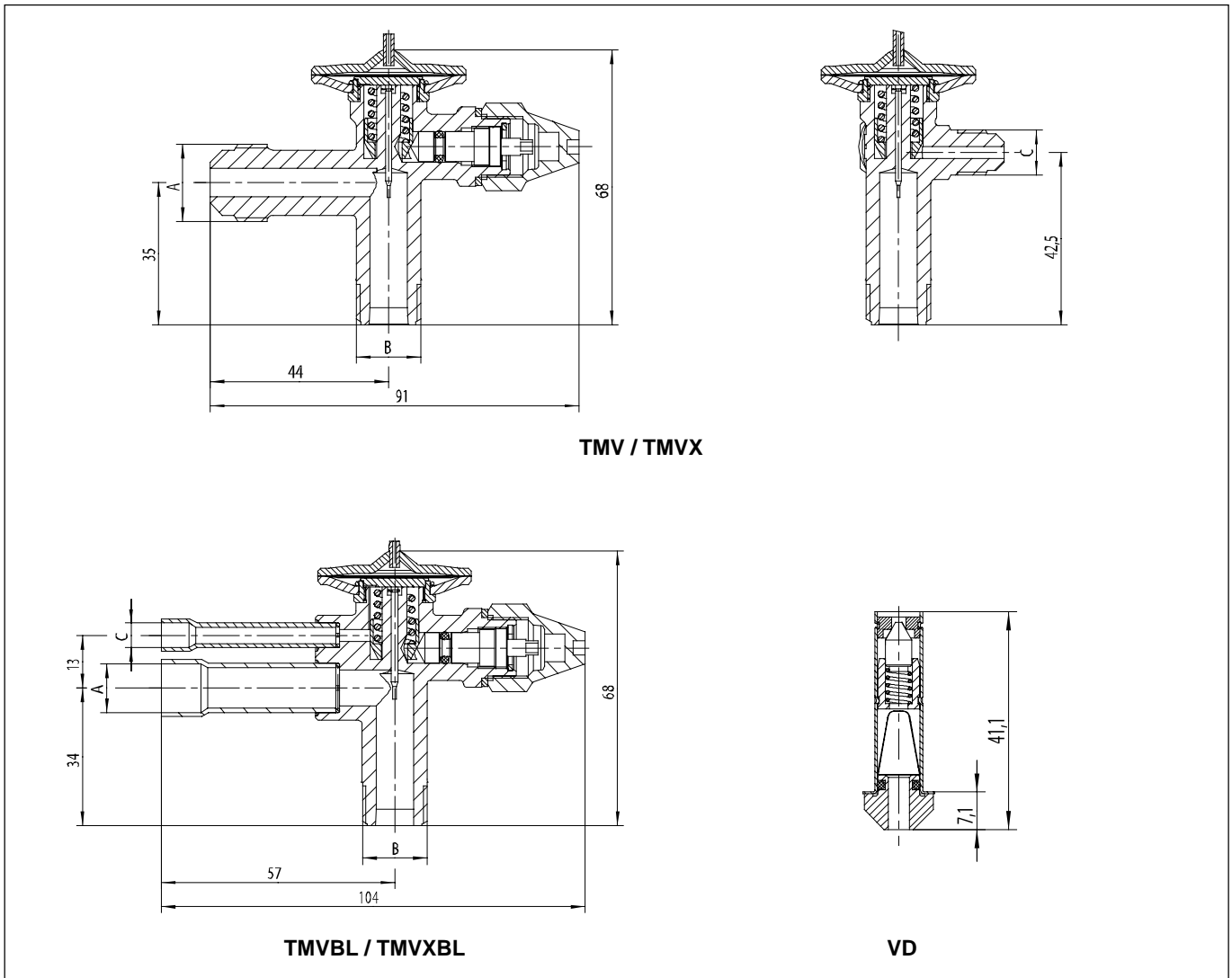

Type Code / Order Information (Part Programme)

1. Valve body

	TMV	X	BL	R134a	MOP A +15 °C	5/8" UNF x 1/2" ODF
Series						
Pressure equalisation: X = external () = internal						
BL = flare x solder connection () = flare connection						
Refrigerant						
Adsorber charge with MOP () = without MOP						
Connection size (inlet x outlet)						

2. Orifice cartridge

	VD	0.5
Series		
Orifice size		

Installation

- The valves may be installed in any position.
- The external pressure equaliser line should be 6 mm or 1/4" in diameter and is to be connected downstream of the remote bulb. An overbowl is recommended in order to prevent the ingress of oil into the equaliser line.
- The bulb should preferably be positioned on the upper half of a horizontal suction line but never after a liquid trap. As a general rule, bulbs of expansion valves should be insulated to prevent them being affected by the ambient temperature.
- Do not bend or squeeze the bulb when tightening the bulb clamp!
- When soldering the valve, the valve body must not get warmer than 100 °C.
- When tightening flare nuts of the flare connections grip at wrench flats on the valve body.
- Constructive modifications at the valve are not allowed.

Superheat Adjustment

In general the Honeywell valves should be installed with the factory setting for the used refrigerant unaltered.

At combi adsorber valves the label on the capillary tube indicates how to adjust the adjusting spindle (with arrow for direction), depending on the refrigerant used. This correction of the adjustment is essential to ensure that the control performance of the valve is correct. The refrigerant used must be marked on the label.

This superheat adjustment is calibrated for lowest superheating and optimum evaporator utilisation. However, should it be necessary to adjust the superheat, turn the adjusting spindle as follows:

Turning clockwise = reduced refrigerant mass flow, increase of superheat

Turning counterclockwise = increased refrigerant mass flow, decrease of superheat

One turn of adjusting spindle alters superheat setting by approx. 0.55 bar. Increase of superheat setting results in a lower MOP-value and vice versa.

Special Accessory:

Adapter series LA for solder connection at the inlet for 6 mm, 10 mm, 1/4", 3/8".

Honeywell

Automation & Control Solutions

Honeywell GmbH
 Hardhofweg
 74821 Mosbach/Germany
 Phone: +49 (0) 62 61 / 81-475
 Fax: +49 (0) 62 61 / 81-461
 E-Mail: cooling.mosbach@honeywell.com
www.honeywell-cooling.com